



**MODULAR DC SERIES**  
**200-DML-1 / 240-DML-1 / 260-DML-1**

**OWNERS MANUAL**

**PAGES**

<b>2</b>	<b>Introduction</b>
<b>3</b>	<b>Specifications</b>
<b>4-5</b>	<b>Standard System Features, Options and Accessories</b>
<b>6</b>	<b>Flow Diagram</b>
<b>7-10</b>	<b>Installation Instructions</b>
<b>11</b>	<b>Installation Instructions Options</b>
<b>12-13</b>	<b>System Operation, Shut Down and Flush Procedure</b>
<b>14</b>	<b>Membrane Storage and Cleaning Procedure</b>
<b>15</b>	<b>Maintenance Timetable</b>
<b>16</b>	<b>Troubleshooting Guide</b>
<b>17</b>	<b>Membrane Element and End Plug Service Instructions</b>
<b>18-19</b>	<b>High Pressure Pump Service Instructions</b>
<b>20-21</b>	<b>Warranty</b>

## INTRODUCTION

Congratulations on the purchase of your ECHOTec Watermaker. We trust that you will be completely satisfied with our product. We thoroughly bench test every desalination system before shipping and are confident that we have manufactured the finest watermaker on the market.

Your watermaker will provide you with clean and safe drinking water for many years to come if you follow the simple instructions in this owners' guide. The purpose of this manual is to allow you to become familiar with each component of your new ECHOTec Watermaker.

By understanding the function, importance and normal operation of each part in the system, the operator can readily diagnose problems when they first develop. Such problems are easily corrected and require minor adjustments. If left unattended, a small problem in one component may affect the rest of the system and can lead to an expensive repair.

If you have any questions regarding the installation, operation or maintenance of your watermaker please contact us. We are always happy to assist!

### **ECHO MARINE LTD.**

1st Avenue South, Chaguaramas, Trinidad W.I.  
Telephone: 1-868-634-2027 Fax: 1-868-634-2026  
E-mail: [echotec@echo-marine.com](mailto:echotec@echo-marine.com)  
[www.echotecwatermakers.com](http://www.echotecwatermakers.com)

## SPECIFICATIONS

### RATED PERFORMANCE:

ECHOTec Model	Gallons per hour	Liters per hour
200 - DML - 1	8.5	32
240 - DML - 1	11	42
260 - DML - 1	13	50

Reverse Osmosis performance varies with the feed water temperature and salinity. The rated performance is tested at 26°C / 80°F water temperature and 33g NaCl/ltr.

### RO MEMBRANE TYPE:

Standard size high rejection TFC Polyamide, thin film composite, spiral wound, single pass reverse osmosis element.

**PRODUCT WATER QUALITY:** minimum 500 ppm TDS

**FEED WATER SALINITY RANGE:** up to 50,000 ppm TDS ( NaCl )

**PH RANGE:** 4 – 11

**CHLORINE TOLERANCE:** 1000 ppm hours

**FEED WATER PRESSURE:** 5”Hg to 60 psi

**OPERATING PRESSURE:** 900 psi

**FEED WATER TEMPERATURE RANGE:** min. 33°F / 0.5°C, max 113°F / 45°C

### ELECTRICAL POWER REQUIREMENTS:

ECHOTec Model	amps @ 12.5 V DC	amps @ 25 V DC	amps @ 48 V DC
200 - DML - 1	19.8	9.5	n/a
240 - DML - 1	27	13.5	n/a
260 - DML - 1	38	18	9

## STANDARD SYSTEM FEATURES

- 1) **1 PVC sea strainer**  
2 3/4" NPT x 5/8" barbed hose connection
- 2) **Pre-Filter** complete with 20 micron cartridge (5 and 20 micron with optional boost pump)  
1 Stainless steel bracket with 8 screws  
1 Service valve with 1 Nylon nipple and 3 barbed hose connectors (with boost pump) or  
1 flush/storage valve with 1 Nylon nipple and 1 NPT female tee (without boost pump)  
1 Filter wrench
- 3) **1 High-pressure pump unit** with vibration dampers
- 4) **1 Pressure vessel with reverse osmosis membrane**
- 5) **1 Stainless steel control panel** completely assembled with  
1 Pressure control valve  
1 High pressure gauge  
1 Product flow meter  
1 Diverter (3-way) valve  
1 Breaker (without boost pump) or  
2 Breakers (with boost pump)
- 6) **1 Hardener / pH neutralizer kit** with mineral element and 2pcs 3/8" compression fittings  
1 Stainless steel bracket with 8 screws
- 7) 15 feet / 4.5 meter high pressure hose with 2 x stainless steel high pressure fittings attached  
2 x stainless steel field attachable high pressure fittings
- 8) 20 feet / 6 meter 3/8" blue product water tubing  
10 feet / 3 meter 5/8" braided intake hose  
10 feet / 3 meter 1/2" braided reject hose or 10 mm tubing
- 9) 17 Stainless steel hose clamps (with boost pump) or  
12 Stainless steel hose clamps (without boost pump)

## OPTIONS AND ACCESSORIES

If the high-pressure pump is installed less than 1 foot below the waterline or an additional 5micron pre-filter is added, the installation of an optional boost pump is recommended. The boost pump also extends pre-filter element life, reduces maintenance and assists in priming the system after pre-filter changes.

**Boost pump** with intake hose barb, outlet hose barb, 4 feet / 1.2 meter wire reinforced intake hose, 10 feet / 3 meter braided feed hose, 5 micron pre-filter housing, bracket, fittings and cartridge (all assembled).



**Fresh water flush kit for installation with boost pump** (filter housing, charcoal cartridge, stainless steel bracket, 8 screws, shut off valve, 2 x 1/2" hose barb connectors, 1/2" tee, 10ft 1/2" braided hose, 5 x 1/2" hose clamps)

**Fresh water flush kit for installation without boost pump** (filter housing, charcoal cartridge, stainless steel bracket, 8 screws, shut off valve, 2 x 5/8" hose barb connectors, 5/8" tee, 10ft 5/8" braided hose, 5 x 5/8" hose clamps)

### Low pressure gauge

The low pressure gauge indicates when the pre-filters have to be changed. Select pressure range according to freshwater pressure.



**5 Micron Pre-filter Housing** (1 filter housing, 1 pre-filter cartridge, 1 bracket, 1 3/4" NPT nipple)

An additional 5 micron pre-filter is only recommended in connection with the optional boost pump.

**Note:** The 5micron filter must be installed as a second filter in flow direction

### Maintenance Kit

- 10 Pre-filters, 5 and/or 20 microns
- 1 Spare sea strainer screen
- 2 Active carbon filters (fresh water flush)
- 1ltr. High pressure pump oil

### Extended Maintenance Kit

- 2 Motor brushes
- 1 Acid cleaning compound
- 1 Alkaline cleaning compound
- 2 Storage compounds (Biocide)
- 1 Complete spare seal and O ring kit (except high pressure pump)

# FLOW DIAGRAM

Shown with Optional Equipment

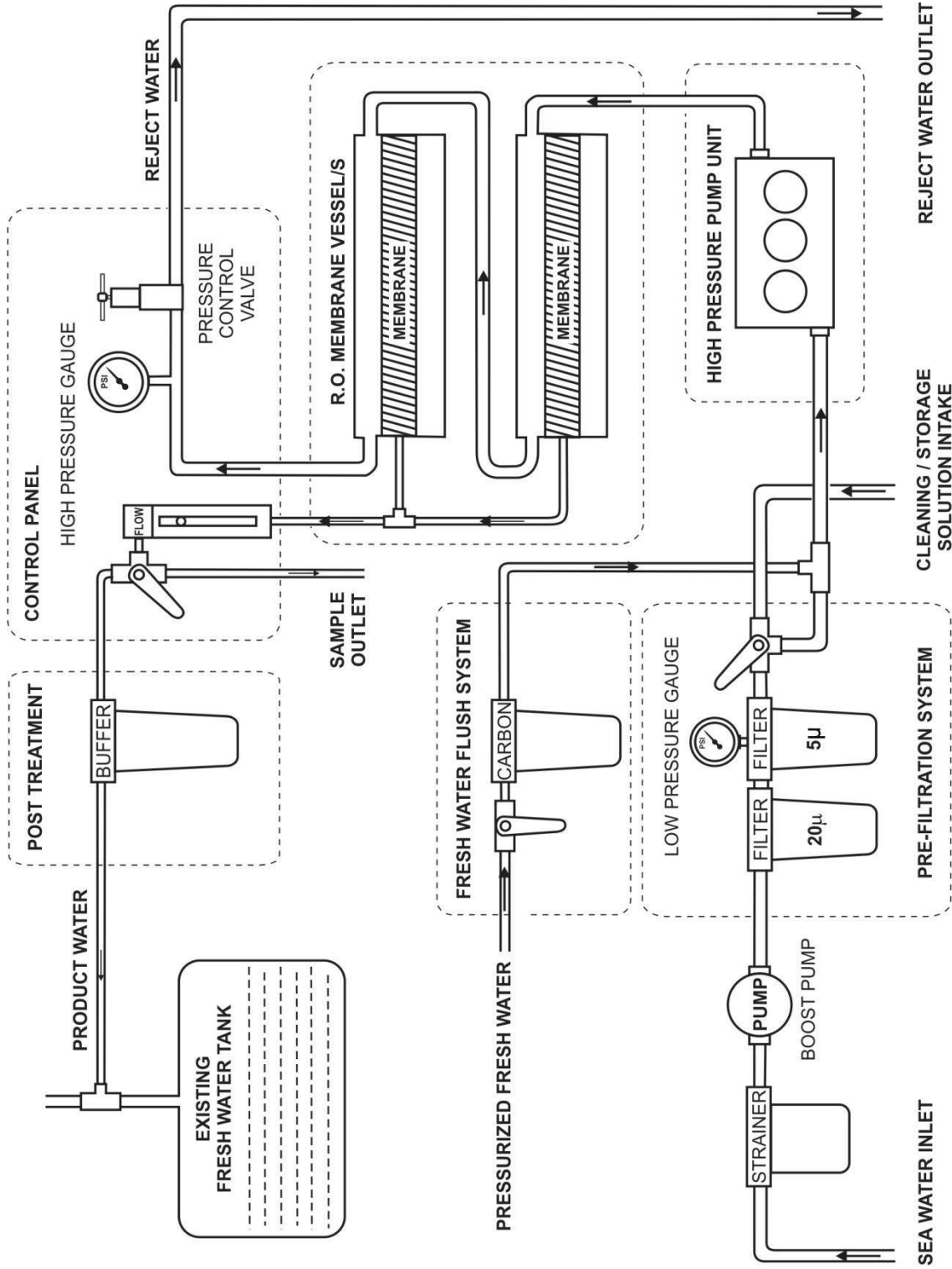

ECH <sub>2</sub> O Tec. <i>Watermakers</i>	SYSTEM	DATE	REV.	DRWN
	MODULAR-SERIES	19/11/2012	3.4	MS

# INSTALLATION INSTRUCTIONS

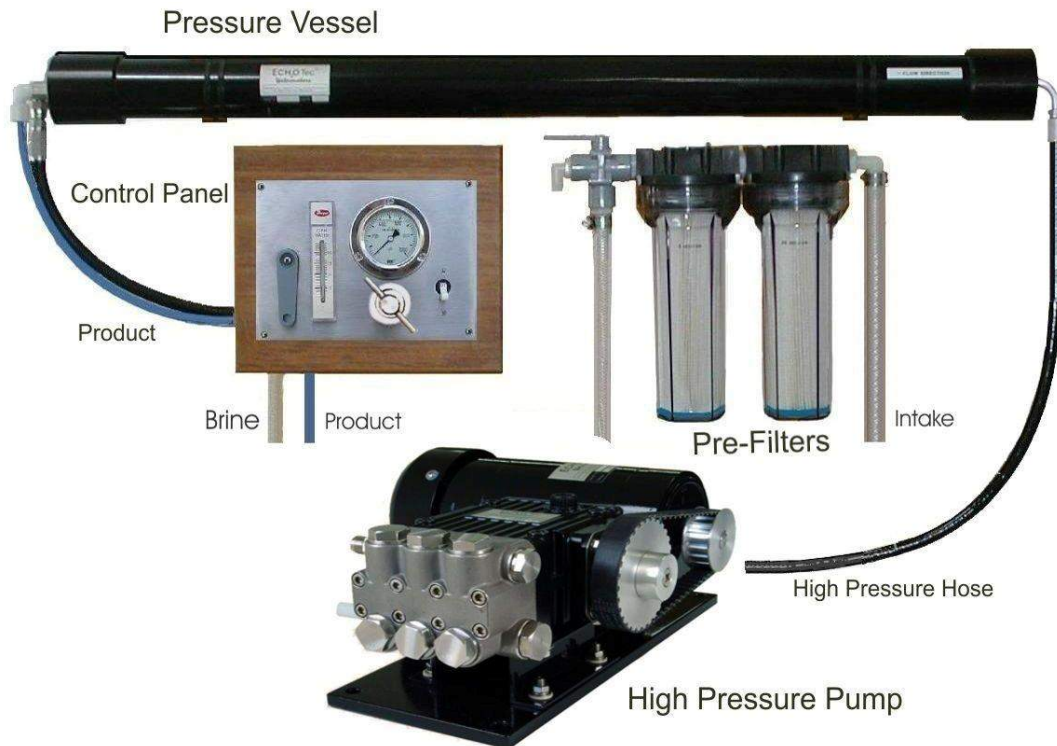

## HIGH PRESSURE PUMP UNIT

Mount the high pressure pump/motor unit horizontally in a dry and ventilated location. Maximum ambient temperature for continuous duty is 40°C / 104°F.

**CAUTION: Motor gets hot during prolonged operation.**

## PRESSURE VESSEL (MEMBRANE HOUSING)

Mount the pressure vessel(s) with the provided brackets vertical (with the flow upwards) or horizontal in a convenient location away from the heat of the engine as close as possible to the high pressure pump.

The membrane is sealed within its housing by plugs at both ends. Inside the housing is a small amount of preservative to keep the membrane moist and prevent bacterial growth. The shelf life of the preservative, under best conditions, is one year.

When all other components and hoses/tubes are completely assembled, remove the caps on the high pressure fittings and the sealed tube from the product water outlet on the membrane housing/s and then finish making all final hose/tube connections. This will insure that the membrane is kept moist.

## CONTROL PANEL

Mount the control panel preferable through a bulkhead or on any panel in an easily accessible location as close as practical to the membrane housing(s).

## SEA STRAINER



Mount the sea strainer with the provided 3/4" NPT nylon nipple directly to the intake of the 20 micron pre-filter housing. If an optional boost pump is required (refer to "Available Options and Accessories"), mount the sea strainer in a serviceable location in between the sea-cock of your choice and the boost pump.

**CAUTION: To avoid excessive mechanical stress, do not mount the sea strainer directly to the sea-cock.**

Connect the barbed fittings with the supplied coil reinforced intake hose and secure all hoses below water level with two hose clamps. For boost pump installation refer to the installation instructions for optional equipment (page 11).

## FILTER HOUSINGS

Mount the pre-filter in a serviceable location and connect the bottom port of the cleaning / storage valve with the 5/8" reinforced vinyl hose to the intake hose barb fitting of the high-pressure pump (lower fitting). Secure the hose with hose supplied clamps.

**CAUTION: Install all plumbing to eliminate any air pockets in the system.**

**CAUTION: If you have to re-seal NPT fittings, use a maximum of three wraps of Teflon tape on the threads. Always keep the tape back from the end of the fittings (at least two threads). Do not allow any tape to enter the system.**

## HIGH PRESSURE HOSE

The high pressure hose has factory mounted high pressure couplings on each end (also included are two field attachable fittings). This hose comes in a 15 feet / 4.5 m length, so it may be cut to suit your needs. Leave a little extra length of hose to avoid stress on the system components.

**CAUTION: Never bend the high pressure hose tighter than a 6"/15 cm radius.**

### Assembly instructions for the stainless steel field attachable high-pressure couplings

- 1) Cut the hose in a clean 90° angle preferably with a cutting disc or fine tooth hacksaw.
- 2) Un-assemble the coupling (remove threaded inner part from outer part).



- 3) Rotate the socket (outer part) anti clock wise on to the hose until hose bottoms. Back the hose out ½ turn to allow for expansion of the hose during assembly.
- 4) Apply dishwashing liquid mixed 1:1 with water on to the nipple (inner part) of the high-pressure fitting and the inside of the hose.
- 5) Hold the socket preferably in a vice and screw the nipple all the way into the hose. The straight fitting is supplied with a hexagonal plug as an assembly tool.

Run one of the high-pressure hoses from the output of the HP pump (O ring sealed fitting) to the O ring sealed fitting at the end of the membrane that is marked IN.

**CAUTION: A minimum hose length of 3 feet / 1m is required for pulsation dampening. The hose can be coiled where needed.**

Run the second high-pressure hose from the outlet of the RO membrane housing to the pressure control valve in the control panel. Do not over tighten the high pressure fittings. They are O-ring sealed and need little torque to lock only.

**CAUTION: When connecting the high pressure hose to the membrane housing (s), avoid over tightening. The fitting is o-ring sealed and does not require much torque.**

## PRODUCT WATER TUBING

Using the blue product water tubing, connect the center fitting of the membrane housing with the bottom fitting (inlet) of the flow meter in the control panel. Connect the tubing or hose from each output port of the 3-way valve to your water tank and to the taste/test station of your choice.

**CAUTION: Under no circumstances should the product water line be allowed to become blocked while the system is running. Do not install shut-off valves anywhere in this line.**

**CAUTION: Do not allow chlorinated water from your storage tank to flow back into the R.O. membrane.**

You may directly “T” your product water line into the tank vent (Refer to the Flow Diagram). This avoids chlorinated water to back flow from your water tanks into the R.O. membrane and does not require a new fitting in your tank. This solution requires a vent of sufficient diameter as the product water will have to flow against the escaping air. If the product line must be installed below tank water line, an optional non-return valve should be installed.

An existing hand pump style spigot, with a check valve only can be used as test station. If using this type of spigot for two sources (tank and test), install low-pressure non-return valves in the tank- and product line and “T” both into the existing hand pump spigot.

## HARDENER / PH NEUTRALIZER KIT



The ECHOTec post treatment element contains a mixture of minerals that returns bicarbonate alkalinity, correcting pH only enough to reach a neutral equilibrium. This dramatically reduces corrosion on metal tanks, boilers, washing machines and plumbing due to acidic product water.

Install the hardener / pH neutralizer housing at a serviceable location in line with the product water tubing from the diverter valve on the control panel to the freshwater storage tank. (Refer to flow diagram on page 6)

**Note:** Observe the flow direction indicated on the housing.

### REJECT WATER TUBING / HOSE (BRINE)

Connect the outlet of the pressure control valve on the control panel with a reject thru-hull of your choice (preferably above the water line as an indication for proper operation of the system).

### THROUGH-HULL FITTING (not supplied)



The boat's designated intake thru-hull should be located in an area that will always be in the water when the boat is used under normal running conditions,

A trough hull fitting with strainer scoop could be helpful. Installed with the opening facing the bow, it typically generates a small amount of pressure while moving through the water. It is important not to place the thru-hull fitting directly forward of a speedometer pickup. It is also wise not to place the intake thru-hull slightly aft or outboard of a holding tank, head or galley sink overboard discharge.

## ELECTRICAL INSTALLATION

The electrical installation should only be done by a professional electrician according to the local regulations with regards to safety. Electrical installation materials are not supplied.

# INSTALLATION INSTRUCTION – OPTIONAL EQUIPMENT

## BOOST PUMP

Install the submersible boost pump with the electric motor sideways (horizontal) **below** the water line, in between the sea strainer and the pre-filter(s). The intake is at the center of the pump. The outlet should ideally point upwards or sideways with the fitting to the top to prevent air pockets.

Avoid elbows/90° fittings in your plumbing if possible. The complete pump head can be turned in case the outlet direction is not suitable for your installation.

The ECHOTec “Orbital” Magnetic Drive Pumps eliminate the conventional shaft seals found in most pumps. This means that there is no rotating seal to wear and allow the liquid being pumped to leak out.

We rely on the liquid being pumped to lubricate the impeller-magnet assembly spinning on the stationary spindle. If the pump is run dry for longer than 10 minutes, the assembly may “freeze” onto the spindle.

All pumps can be serviced with the use of a screwdriver. The only moving part in the pump other than the motor is the impeller-magnet assembly. This assembly rotates on a stationary spindle and up against a thrust washer.

**Note:** The boost pump includes the 5 micron pre-filter option.

## 5 MICRON PRE-FILTER

Connect the filter housing with the supplied ¾” nylon nipple to the standard filter housing and reconnect the reinforced vinyl hose. The 5micron cartridge has to be installed as the second filter in flow direction.

## 5 MICRON PRE FILTER WITH LOW PRESSURE GAUGE

The optional 5micron pre filter housing with low pressure gauge has to be installed as a second filter in flow direction.

## FRESHWATER FLUSH SYSTEM

Install the active carbon filter housing at an easily accessible location close to your seawater intake line and any pressurized water line. Connect the fitting on the shut off valve of the carbon filter housing to your boats’ pressurized water line.

Connect the filter outlet to the supplied T-connector. Connect the two remaining ports of the T-connector to the outlet of the storage/cleaning valve on the pre-filter housing and to the intake of the high pressure pump (refer to the flow diagram).

## SYSTEM OPERATION INSTRUCTIONS

**CAUTION:** The reverse osmosis membrane contains a preservative solution to prevent microbiological growth. If ingested, it may cause irritation of the gastro-intestinal tract. Therefore, discard all the product water for at least thirty minutes of initial operation or after system storage before drinking or before use in food preparations!

**CAUTION:** Do not operate the system using contaminated feed water sources (oil, chlorine or other chemicals).

**CAUTION:** Check proper oil level with dipstick or show glass (center of show glass).

**CAUTION:** Have you removed the shipping plug from the high pressure pump and replaced with the enclosed breather oil cap? Failure to do so may damage the crankshaft oil seals of the pump.

- 1) Open the seawater intake valve (sea cock).
- 2) Open the pressure control valve, on the control panel, all the way counter-clockwise.

**CAUTION:** Never start the system with the high-pressure control valve closed.

- 3) Set the cleaning/storage valve to the pre-filter position (towards the filter).
- 4) Set the diverter valve to sample position (left).
- 5) Switch on the boost pump (optional).
- 6) Switch on the high pressure pump.
- 7) Flush the air out of the system. Crack open pre- filter housings if needed.

Check for brine discharge at the output location.

**CAUTION:** Never allow any leaks in your hose or tube connections.

**CAUTION:** Do not attempt to re-seal the stainless steel product water outlet fitting on the membrane vessel end cap by further tightening as this could damage the thread of the plug. Remove the fitting, apply new Teflon tape, insert the fitting and hand tighten plus ¼ turn.

- 8) Close the pressure control valve slowly clockwise to allow air bubbles to work themselves out of the system.
- 9) Adjust the water pressure to achieve the specified product output with a maximum reading of 900 PSI on the pressure gauge in the control panel. If you operate the watermaker in brackish or lake water, adjust the working pressure not to exceed the specified product water rate.
- 10) Taste the product water at your sample station. If the water is pure, switch the diverter valve to fill your storage tank.

## **SYSTEM SHUT DOWN PROCEDURE**

- 1) Switch the diverter valve to sample station.
- 2) Open the pressure control valve all the way counter-clockwise.
- 3) Switch off the electric motor and the boost pump (if installed).
- 4) Close the seawater intake valve.

## **FRESH WATER FLUSH PROCEDURE**

The fresh water flush prepares your watermaker for a shut down period of ten days. It can be repeated indefinitely as an alternative to the chemical long term storage of the membrane element.

**CAUTION:** The boats fresh water pressure should not exceed the range of the low pressure gauge.

- 1) Open the pressure control valve all the way (two full rounds after the spring releases) counter clockwise.
- 2) Close the sea water intake valve or switch the cleaning/storage valve to the closed position.
- 3) Open the fresh water flush valve.

Your boats' fresh water supply pump should now turn on (larger fresh water pumps will cycle on and off). Allow fresh water to flow until all salt water is flushed out of the RO System. For the next flush procedure, test how long it takes until the brine at the outlet becomes fresh.

## **PRE-FILTER BACKWASH PROCEDURE**

As part of a long term storage, you may remove the pre-filter cartridges from the housings or perform a pre-filter backwash procedure. If there is no momentary shortage of fresh water, the back wash may also be useful to reduce product water discharge time until the product is free of odor after each start up.

- 1) Open the seacock and switch the cleaning/storage valve to the sea water position.
- 2) Allow fresh water to flow until all salt water is flushed out of the pre-filter(s), boost pump and the sea strainer (approximately 30 seconds, depending on the flow rate of your vessel's fresh water pump).
- 3) Close the seacock.

## **MEMBRANE STORAGE PROCEDURE**

If you intend to store your watermaker for more than ten days, growth of micro-organism may degrade the RO membrane(s) performance and the RO membrane(s) should be flushed with a biocide solution. This will preserve the membrane for long-term storage of up to ten months.

If you have installed the optional fresh water flush system, it is recommended to back flush the pre-filter(s), the boost pump and the sea strainer with fresh water (see above). Close the seawater intake valve (sea cock) and remove the pre-filter cartridge(s).

- 1) In a clean plastic container, mix 2.5 gallons / 10 liters of un-chlorinated fresh water with 100 grams (1/3 container) of ECHOTec membrane preservative # 3 (Metabisulfite)
- 2) Switch the three-way valve to the cleaning/storage position.
- 3) Switch the diverter valve to the sample position.
- 4) Open the pressure control valve all the way counter clockwise (two full rounds after the spring releases).
- 5) Use a large funnel or open container with barbed fitting to pour the solution into the cleaning/storage hose or lead the hose into an elevated plastic container while running the high-pressure pump. When the solution has been infused, switch off the watermaker.

Your watermaker is now prepared for a shut down period of ten months.

**CAUTION:** After storage, discard the product water for at least thirty minutes of initial operation before drinking or before use in food preparations.

## MEMBRANE CLEANING PROCEDURE

ECHO Tec membrane element may be chemically cleaned when the product water output drops by 15% of the specified amount. The frequency of this occurring will vary greatly depending upon feed water quality. Fouling of the membrane will naturally occur during normal usage. Increased amounts of fouling without proper cleaning of the membrane will reduce the performance of your water maker. A drop in production of approximately 10% is normal and expected during the first year of operation.

**Note:** Do not clean when product salinity high. Clean only to restore output!

**CAUTION:** The use of chemicals or cleaning methods other than those outlined in the cleaning instructions will void the ECHO Tec Warranty.

**CAUTION:** Cleaning chemical #1 is an alkaline detergent. See warning label on side of the container and observe all safety precautions on label.

**CAUTION:** Cleaning chemical #2 is an acid, a mineral scale remover. See warning label on side of container and observe all safety precautions on label.

**CAUTION:** Do not mix different cleaning chemicals together. Do not use different cleaning chemicals together at the same time.

To clean the ECHO Tec. reverse osmosis membrane mix a solution of 1.5 to 2 % by weight with warm non-chlorinated water (113° F / 45° C) in a clean plastic container. Use 10 ltr / 2.5 gal with 200 g or 2/3 container cleaning agent.

For safety reasons, we do not recommend you to install a 3 way re-circulating valve to facilitate the service procedure. Disconnect the intake and reject water hose and lead them in the plastic container. Re-circulate the solution intermittent without pressure for up to 60 min. There will be no flow at the fresh water outlet.

**CAUTION:** Observe the maximum operating temperature of 113° F / 45° C. The high pressure pump might over heat the solution on re-circulating.

It is important that most of the fresh water remaining from the last flush is dumped before the reject hose is led in the cleaning bucket for re-circulation in order to avoid diluting the solution.

Use cleaning chemical #1 first. Only if the performance does not improve, use the acid cleaner #2 at the same ratio and instruction.

## MAINTENANCE TIMETABLE

The following maintenance timetable is an estimate of the time intervals at which maintenance may be required only. This schedule must be adjusted to the regularity of usage, the condition of the intake water, the length of time the system is exposed to seawater and the total running time following each system cleaning.

COMPONENT	MAINTENANCE REQUIRED	TIME INTERVAL (INTERMITTENT DUTY)
Sea Strainer	Inspect and clean screen and housing...	every 200 hrs or when clogged. Observe low pressure gauge if installed.
Pre filters(s)	Replace or clean element(s) and clean housing(s)...	Boost pump: when pressure is lower than 0 PSI. No Boost pump: pressure lower than 5”Hg
Hardener / pH neutralizer	Replace or refilled with the mineral mix of another cartridge...	when 25% of the content has been dissolved to guaranty sufficient contact surface
Carbon flush filter	Replace element...	every 6 months
High pressure pump	Change crankcase oil... 7.5 oz./0.2 L SAE 90 Wt, non-detergent	Initial change after 50 hrs. every 300 operating hours or 12 months
High pressure pump	Change seals and O-rings...	every 5000 hrs or 3 years.
R.O. Membrane	Clean with acid and/or alkaline cleaning compound...  Replace...  <b>Note:</b> Do not clean when TDS reads high. Clean only to restore output!	when production decreases by 15%.  when cleaning does not increase production.
Flow meter	*Infuse muriatic acid and rinse well...	when discolored/dirty

\* Set the diverter valve to the sample position. Disconnect the product water tubing from the product port at the membrane vessel and carefully infuse Muriatic acid, KR1 or Ospho with a syringe into the product water tubing. Once the discoloring has cleared, re-connect the tubing, run the system and rinse the flow meter with the product water. **CAUTION:** Adhere to the safety advises of the cleaning agents.

## TROUBLESHOOTING GUIDE

MALFUNCTION	CAUSE	REMEDY
<p>Inability to build up pressure...</p> <p>...with high pressure gauge fluttering.</p> <p>...with loud noise from HP-pump. (Low pressure gauge reads below 10" Hg)</p> <p>...during navigation</p> <p>...with drop in RPM</p>	<p>Air enters intake plumbing. Air in intake system</p> <p>High pressure pump valve stuck after long storage time.</p> <p>Seacock closed Seacock clogged (Barnacles?) Strainer, filter/s fouled</p> <p>Through hull fitting in wrong location (suction trough movement).</p> <p>Motor brushes worn</p>	<p>Tighten all hose clamps.</p> <p>Allow more time to prime. If no boost pump is installed, perform freshwater flush to assist priming.</p> <p>Open one by one all six hexagonal valve covers. Inspect valves for movement.</p> <p>Open seacock Clean seacock Clean strainer, change/clean filter/s.</p> <p>Use strainer scoop (page 11).</p> <p>Replace brushes</p>
<p>Pressure drops frequently with change of noise...</p> <p>...during navigation</p>	<p>Air enters intake plumbing.</p> <p>Air enters sea water intake during navigation.</p>	<p>Tighten all hose clamps. Reseal NPT fittings.</p> <p>Move through hull fitting to lower location.</p>
<p>Excessive leakage between the high pressure pump head and crankcase...</p> <p>...with water in crankcase</p>	<p>Worn high pressure seals Cracked ceramic plunger</p> <p>Cracked ceramic plunger and/or worn HP/oil seals</p>	<p>Replace high pressure seals</p> <p>Inspect for hairline crack. Replace plunger and HP seals (page 20).</p> <p>Inspect for hairline crack. Replace plunger (if needed), high pressure seals and oil seals.</p>
<p>Product salinity reads above 500ppmTDS.</p>	<p>Membrane element has reached its service life time.</p>	<p>Replace membrane element. See instructions on page 17.</p>
<p>Product output below specification.</p>	<p>Low voltage or bad electrical contact Membrane element clogged or reached its service life time.</p>	<p>Check voltage directly at motor cables.</p> <p>Clean membrane element (page 14).</p> <p>Replace membrane element (page 17).</p>
<p>Leak on pressure vessel end cap from salt water</p> <p>...from fresh water</p>	<p>O-ring worn Product port Teflon seal worn</p>	<p>Remove and inspect plug (page 17). Change O-ring/s as needed.</p> <p>Remove port, re-seal, install hand tight + ¼ turn</p>



## MEMBRANE ELEMENT AND END PLUG SERVICE INSTRUCTIONS

- 1) Remove the high pressure hoses and product tubing from the pressure vessel
- 2) If needed remove the complete vessel
- 3) Remove the three M6 bolts with a 5mm allen key on both sides of the vessel.
- 4) Remove the three locking plates (locks) on both sides.
- 5) Holding the product port, pull the product port end plug in one fast pull out of the vessel.

Note: Should the plugs O-ring (PL01) get stuck in the locks groove of the pressure vessel, it will be more difficult to pull the plug. Tap the plug in and pull more vigorously.

If the product port is mounted on the high pressure **OUT** side:

- 6) Using a needle nose pliers, pull the membrane element on the product tube in flow direction.
- 6b) Push out the remaining end plug from the opposite side with a pipe, boat hook, etc.

If the product port is mounted on the high pressure **IN** side:

- 6) Using a short pipe or wooden support, push out the membrane element together with the remaining end plug.

Inspect the end plugs for hairline cracks or damages on the O-rings and O-ring grooves.

- 7) Insert the new membrane element, observing the correct position and direction of the lipped seal ring: High pressure entry side of the membrane, lip against flow direction.
- 8) If needed, clean the product port and end plug threads from remaining Teflon sealant and re-apply 3 wraps only.
- 11) Insert the end plugs and reassemble all components visa versa.

**CAUTION:** Do not over tightening the product port/s. Hand tide plus  $\frac{1}{4}$  turn. Thread may damage!

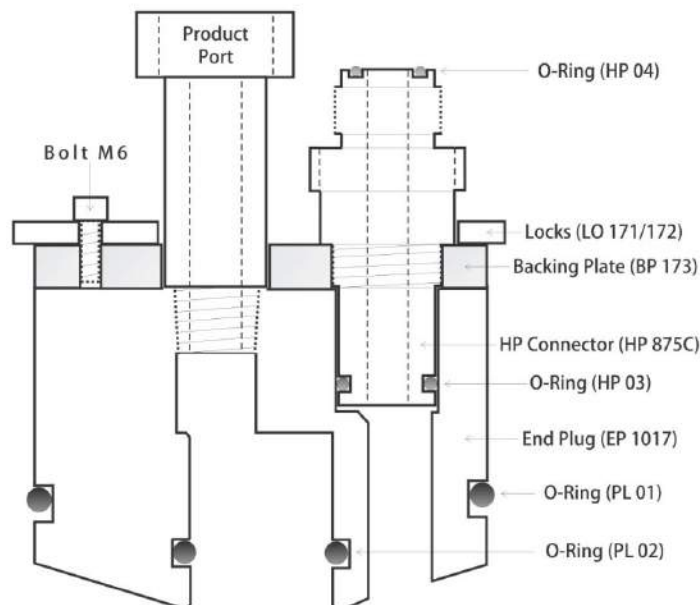

# HIGH PRESSURE PUMP PARTS AND SERVICE INSTRUCTIONS

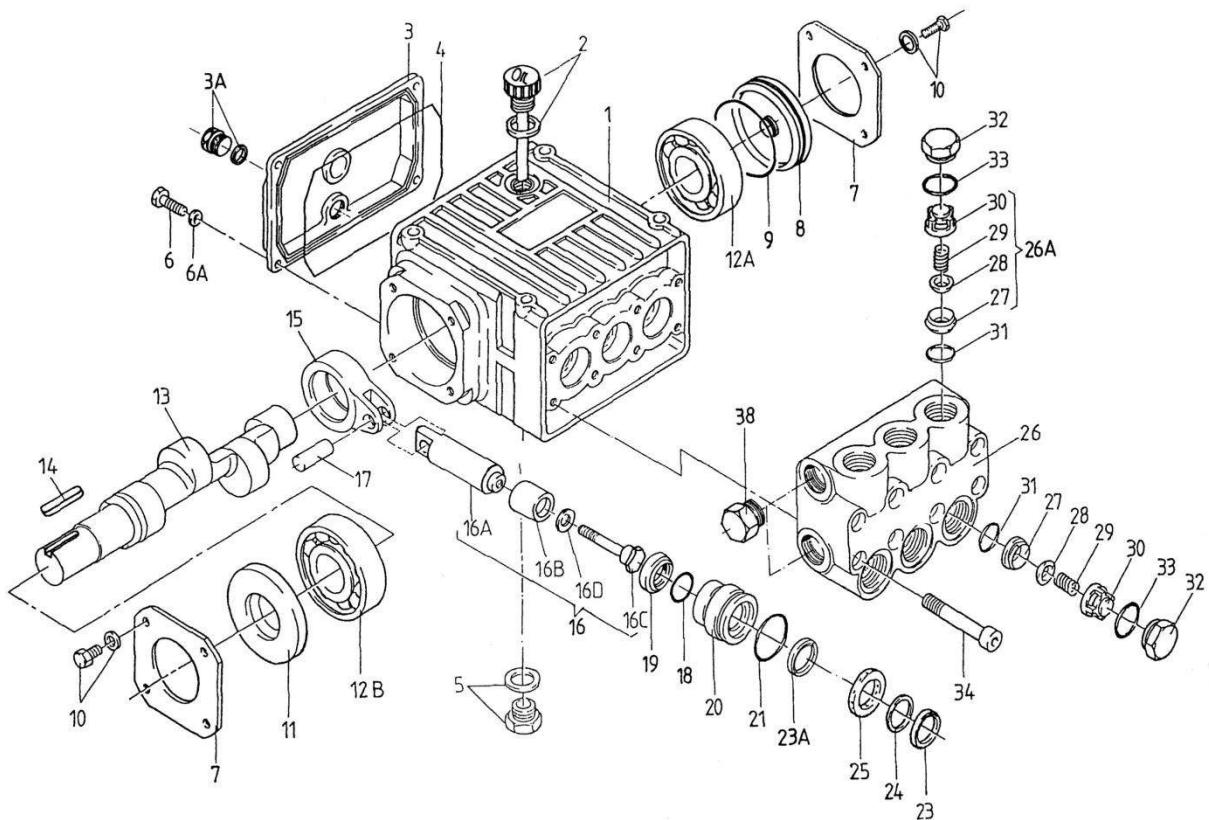

## DISASSEMBLY SEQUENCE OF THE PUMP HEAD

Refer to the pump diagram.

- 1) Remove the three discharge valve plugs and the three inlet valve plugs (32), with a 22 mm socket wrench. Inspect the O-ring (33) for wear and replace if damaged.
- 2) With needle nose pliers, remove the inlet and discharge valve assemblies (32X). Insert a small screwdriver between the valve seat (27) and the valve spring retainer (30) to separate the valve assembly. Remove the O-ring (31). Inspect all parts for wear and replace if necessary.
- 3) Next, use a 5 mm Allen wrench to remove the 8 socket head cap screws (34). Carefully slide the valve casing (26) out over the plungers. Remove the weep return ring (25), pressure ring (24) and V-sleeve with support ring (23), from the valve casing (26). Remove the V-sleeve (23) from the seal case (20). Inspect all parts, including O-ring (21) for wear and replace if necessary.
- 4) Check surfaces of plunger (16). A damaged surface will cause accelerated wear on the seals. Deposits of any kind must be carefully removed from the plunger surface. A damaged plunger must be replaced!
- 5) If the ceramic plunger (16B) is damaged, remove the plunger bolt (16C). Discard the old plunger (16B) and copper gasket (16D) and clean the old Loctite from the plunger bolt (16C) and plunger base (16A). Replace the plunger with the new one and Loctite the plunger bolt and torque to 120 inch-pounds.

**Note:** If there are deposits of any kind (i.e., lime deposits) in the valve casing, be certain that the weep holes in the weep return ring and valve casing have not been plugged.

- 6) If the crankcase oil seals (19) are to be replaced, they can be removed by prying loose. Take care not to make contact with the plunger. If the oil seals are not to be replaced, proceed to the back end disassembly sequence and carefully pry the seals loose after the plungers have been removed from the crankcase.

## DISASSEMBLY SEQUENCE OF THE CRANKCASE

- 1) Before beginning, drain the oil from the crankcase, through the oil drain (3A).
- 2) Remove the crankcase cover (3) and O-ring (4) from the crankcase (1). To remove the crankshaft (13), remove the bearing cover (7) and sight glass (8). Using a rubber mallet, remove the crankshaft axially through the connecting rods by tapping on the end of the shaft. Do not bend or damage the connecting rods during crankshaft removal.
- 3) Next remove the remaining bearing and radial shaft seal (11). Inspect both bearings and seal for wear and replace if necessary.
- 4) Remove the connecting rod (15), then the plunger (16) and wrist pin (17), if necessary. Check the plunger bore in the crankcase for wear. Inspect parts and replace as necessary.
- 5) Should you find it necessary to service the plunger assembly (16), you can do so by removing the tension screw (16D). Inspect all parts and replace as necessary.

**Note:** In order to drive the pump from the side opposite the present shaft extension, simply remove the valve casing from the crankcase and rotate the pump 180 degrees to the desired position. Be certain to rotate the seal case as well, so that the weep holes are down at the six o'clock position. Change the oil fill and the oil drain plugs. Refer to the repair instructions as necessary for the proper assembly sequence.

## REASSEMBLY SEQUENCE

- 1) Reassemble plunger (16) and the connecting rod (15) with wrist pin (17). Place assemblies in crankcase (1). Install crankshaft through connecting rods, again being careful not to bend or otherwise damage the connecting rods.
- 2) Replace left and right side bearings (12A and 12B), if they were removed from the crankshaft. Be certain the bearings are pressed all the way onto the shaft and completely into the crankcase. Replace radial shaft seal (11) bearing cover with sight glass (7 and 8) and crankcase cover with O-ring (3 and 4).
- 3) If oil seals (19) were removed, replace with seal lip towards crankcase. Lubricate seal with silicone grease before replacing.
- 4) Replace seal case (20) with O-ring (21) over plungers. Generously lubricate O-ring and oil seal with silicone grease before reassembly. Replace V-sleeve (23) over plunger.
- 5) Generously lubricate V-sleeve (23). Assemble spacer and V-sleeve (23) into valve casing (26). Assemble weep return ring and pressure ring (25 and 24) over plungers. Slide the valve casing over plungers and seat firmly. Replace the eight-socket head cap screws (34) and tighten to 105 inch pounds in a crossing pattern.
- 6) Replace the six O-rings (31) and the six-valve assemblies (32X). Replace the six valve plugs with O-rings (32 and 33) and tighten securely with a 22mm socket wrench to 33 foot-pounds.
- 7) Fill crankcase with 7.5 ounces / 0.22 ltr non-toxic, non-detergent SAE 90 gearbox oil.

## ECHOTEC WATERMAKERS LIMITED WARRANTY

Echo Marine Ltd. warrants for a period of 3 years (1 year for commercial applications) from the date of shipment that the ECHOTec watermaker is free of defects in material and workmanship and performs according to specifications. The triplex plunger high-pressure pump head and the high pressure vessel/s (except end plugs, O-rings and fittings) are warranted for life (10 years for commercial applications) to the original purchaser.

Echo Marine's liability under this warranty shall be limited to repair or replacement of the ECHOTec watermaker at Echo Marine's option. Under no circumstances shall Echo Marine Ltd. be liable for consequential damages arising out of or in any way connected with the failure of the system to perform as set forth herein. This limited warranty is in lieu of all other expressed or implied warranties, including those of merchantability and fitness for a particular purpose.

In the event of a defect, malfunction, or failure during the warranty period, Echo Marine Ltd. will repair or replace, at its option, the product or component therein which, upon examination by Echo Marine, shall appear to be defective, or not up to factory specifications.

To obtain warranty service, the defective product or part must be returned to Echo Marine's Service Center. The purchaser must pay any transportation or labor expenses incurred in removing and returning the product. A return authorization must be obtained before any part or component is shipped.

The limited warranty does not extend to any system component that has been subjected to misuse, neglect, accident, improper installation, or used in violation of instructions furnished by Echo Marine Ltd. The warranty does not extend to components on which the serial number has been removed, defaced or changed.

Echo Marine Ltd. reserves the right to make changes or improvements in its product during subsequent production without incurring the obligation to install such changes or improvements on previously manufactured equipment.

The implied warranties, which the law imposes on the sale of this product, are expressly LIMITED, in duration to the time period above. Echo Marine shall not be liable for damages, consequential or otherwise, resulting from the use and operation of this product or from the breach of this limited warranty.

This limited warranty service does not apply to normal recurring user maintenance as described below.

Sea Strainer Element	Pump Valve Assemblies
Pre-filter Cartridges	Gauge/Instrument Calibration
Auxiliary Tubing	Pump Crankcase Oil
Pump Seals and Packings	V or Timing Belt
Pump Bushings and Bearings	

The ECHOTec Membrane Element is warranted to be cleanable for a minimum of one year from date of shipment, provided that cleaning instructions are adhered to and foulant is acid soluble metal hydroxides and calcium carbonates or alkaline soluble organic, inorganic substances and microbiological slimes. The ECHOTec Membrane Element is not warranted against iron fouling (rust), chemical attack, extreme temperatures (over 120° F/49°C and under 32°F/0°C), drying out, or extreme pressures (over 1000 psig/68bar).

**CAUTION:** Use of parts not supplied directly by Echo Marine (generic parts), including but not limited to maintenance parts, pre-filter elements, cleaning and storage chemicals, pump oil, spare parts, replacement parts, system components and or system accessories, shall void all warranties expressed or implied unless agreed in writing.

ECHOTec desalination systems are shipped complete with reverse osmosis membrane element(s) installed. However, if the ECHOTec system will not be put to use within 10 months of shipment, there is a potential danger of the membrane element(s) fouling. Therefore, we offer to ship your system without the membrane element(s). This allows installing the desalination system at the appropriate refurbishing or production schedule without risk to the membrane element(s). Echo Marine Ltd. will ship the reverse osmosis membrane element(s) when notified that the ECHOTec desalination system is ready for commissioning. This service is available upon request.

The warranty on the ECHO Tec Watermaker is activated upon shipment of the system with the reverse osmosis membrane element(s) installed. However, by shipping the watermaker without the reverse osmosis membrane element(s), the warranty period will start upon shipment of the membrane element(s), with a maximum delay of 12 months from the date of purchase.

## **ECHO MARINE LTD.**

1st Avenue South, Chaguaramas, Trinidad W.I.  
Telephone: 1-868-634-2027 Fax: 1-868-6342026  
E-mail: [echotec@echo-marine.com](mailto:echotec@echo-marine.com)  
[www.echotecwatermakers.com](http://www.echotecwatermakers.com)